

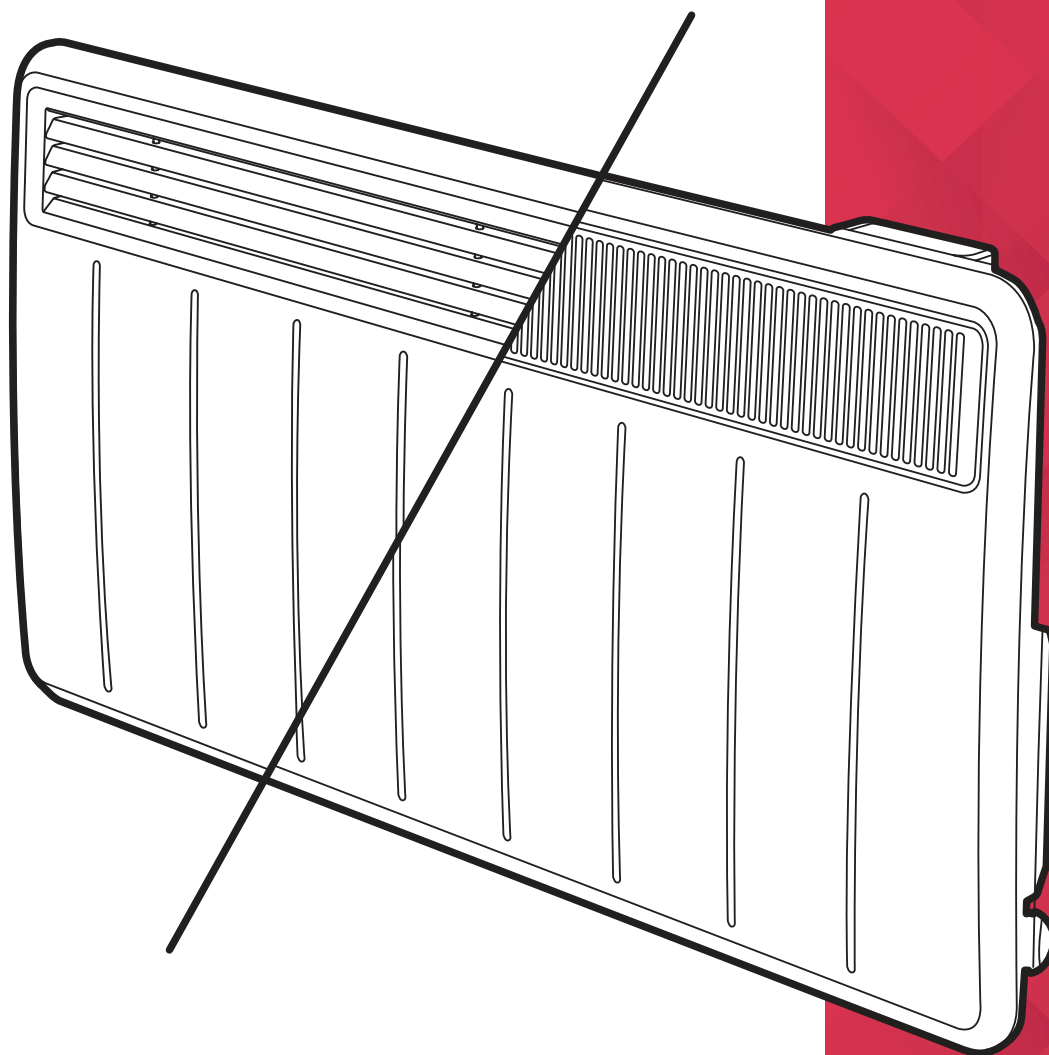

INSTRUCTION MANUAL

Installation and Operating



PLXE Panel Heater

Models: PLX050E / PLX075E / PLX100E /
PLX125E / PLX150E / PLX200E / PLXC300E/
PLX125E SDM

*Note: PLXC300E features a slotted grille



IMPORTANT

THESE INSTRUCTIONS SHOULD BE READ CAREFULLY AND RETAINED FOR FUTURE REFERENCE. **Note also the information presented on the appliance**

IMPORTANT SAFETY ADVICE

When using electrical appliances, basic precautions should always be followed to reduce the risk of fire, electrical shock, and injury to persons, including the following:

IMPORTANT: The wall bracket supplied with the appliance must be used.

WARNING: DO NOT USE THIS HEATER IN THE IMMEDIATE SURROUNDINGS OF A BATH, A SHOWER OR A SWIMMING POOL.

IMPORTANT: If the heater is installed in a room containing a bath or shower, it must be installed so that switches and other controls cannot be touched by a person using a bath or shower.

Do not use outdoors.

Do not locate the heater immediately below a fixed socket outlet or connection box.

WARNING: In order to avoid overheating, do not cover the heater. Do not place material or garments on the heater, or obstruct the air circulation around the heater, for instance by curtains or furniture, as this could cause overheating and a fire risk.

NEVER cover or obstruct in any way the heat outlet slots at the top of the heater or the air inlet slots in the base of the heater.

The heater carries a warning '**DO NOT COVER**' to alert the user to the risk of fire that exists if the heater is accidentally covered.

CAUTION: Some parts of this product can become very hot and cause burns. Particular attention has to be given where children and vulnerable people are present.

This appliance can be used by children aged from 8 years and above and by persons with reduced physical, sensory or mental capabilities or lack of experience and knowledge if they have been given supervision or instruction concerning use of the appliance in a safe way and understand the hazards involved.

Children shall not play with the appliance. Cleaning and user maintenance shall not be made by children without supervision.

Children of less than 3 years should be kept away unless continuously supervised. Children aged from 3 years and less than 8 years shall only switch on/off the appliance provided that it has been placed or installed in its intended normal operating position and they have been given supervision or instruction concerning use of the appliance in a safe way and understand the hazards involved. Children aged from 3 years and less than 8 years shall not plug in, regulate and clean the appliance or perform user maintenance.

Note that due care and consideration must be taken when using this heater in series with a thermal control, a program controller, a timer or any other device that switches on the heat automatically, since a fire risk exists when the heater is accidentally covered or displaced.

If the supply cord is damaged it must be replaced by the manufacturer or service agent or a similarly qualified person in order to avoid a hazard.

WARNING: Servicing and product repairs should only be undertaken by the manufacturers approved service agent or a similarly qualified person, using only exact manufacturer approved spare parts.

WARNING: THIS APPLIANCE MUST BE EARTHED

The electrical installation must be carried out by a competent electrician, and be in strict accordance with the current I.E.E. Regulations for Electrical Equipment in Buildings. The wires in this mains lead are coloured in accordance with the following code:

GREEN AND YELLOW: EARTH

BLUE: NEUTRAL

BROWN: LIVE

The heater is fitted with a length of flexible cable type H05VV-F, size 3 x 1.0mm² for 500W to 2000W and 3 x 1.5mm² on 3000W models, for connection to the fixed wiring of the premises through a suitable connection box positioned adjacent to the heater.

A means for disconnection must be incorporated in the fixed wiring of the premises in accordance with the wiring rules. The supply circuit to the heater must incorporate a double pole isolating switch having a contact separation of at least 3mm.

DO NOT USE THIS HEATER IF IT HAS BEEN DROPPED.

DO NOT USE IS THERE ARE VISIBLE SIGNS OF DAMAGE TO THE HEATER.

USE THIS HEATER ON A HORIZONTAL SURFACE, OR FIX IT TO THE WALL AS APPLICABLE.

WARNING: Do not use this heater in small rooms when they are occupied by persons not capable of leaving the room on their own, unless constant supervision is provided.

WARNING: To reduce the risk of fire keep textiles, curtains or any other flammable material a minimum distance of 1 metre from the air outlet.

Supplementary Earth Bonding

Should Equipotential Earth Bonding be required the earthing conductor in the supply cord is deemed to provide the supplementary bonding connection (see Regulation 544.2.5, 17th Edition I.E.E. Wiring Regulations).

Please note that lit cigarettes, candles and oil burners, combined with the convection effect of electric heaters can cause soot deposits to build up on the surface directly above and to the sides of the heater. This is not a fault of the heater. Extensive burning of candles or smoking in the operating environment of this product can produce heavy discolouration within a few months of use.

Energy Related Product Directive

Product information according to Ecodesign Regulation (EU) 2015/1188

Model Identifier(s):		PLX050E	PLX075E	PLX100E	PLX125E/ PLX125E SDM	PLX150E	PLX200E	PLXC300E
Heat Output								
Nominal heat output	P _{nom}	0.50kW	0.75kW	1.00kW	1.25kW	1.50kW	2.00kW	3.00kW
Minimum heat output (indicative)	P _{min}	N.A	N.A	N.A	N.A	N.A	N.A	N.A
Maximum heat output	P _{max,c}	0.50kW	0.75kW	1.00kW	1.25kW	1.50kW	2.00kW	3.00kW
Auxiliary electricity consumption								
At nominal heat output	e _{lmax}	0.00	0.00	0.00	0.00	0.00	0.00	0.00
At minimum heat output	e _{lmin}	0.00	0.00	0.00	0.00	0.00	0.00	0.00
In standby mode	e _{lSB}	<0.0005	<0.0005	<0.0005	<0.0005	<0.0005	<0.0005	<0.0005
Type of heat output / room temperature control								
Electronic heat charge control with room and / or outdoor temperature feedback					Yes			
Other control options								

Contact details

Glen Dimplex Heating and Ventilation

Millbrook House, Grange Drive, Hedge End, Southampton, SO30 2DF

Tel: 0344 879 3588

This product meets the Ecodesign requirements for an electric storage local space heater. Commission Regulation (EU) 2015/1188.

Technical Details

Model Identifier(s):	PLX050E	PLX075E	PLX100E	PLX125E	PLX150E	PLX200E	PLXC300E	PLX125E SDM
Width 'D' (mm)	450	620	620	690	690	860	860	690
Height 'E' (mm)	430	430	430	430	430	430	430	430
Depth 'F' (mm)	108	108	108	108	108	108	143	108
'A'	116	286	286	356	356	526	526	356
'B'	269	269	269	269	269	269	269	269
'C'	365	365	365	365	365	365	365	365

All Models

Controls	Digitally controlled, Electronic Thermostat accurate to (30.2°C) Timer modes: 7 Day Programmable User Timer, Out All Day, Home All Day, Continuous heat modes: Eco, Manual, Frost Protect Additional Modes: Away, Boost, Setback
Controller UI	<ul style="list-style-type: none"> • Graphical display with RGB backlight • Capacitive buttons with audio feedback • User replaceable battery (Coin-Type: CR2032) • Open window detection, Adaptive-start, Advance time period • Wide SP range (7-30°C) • Bluetooth for software updates • Child Lock & Heater Lock (PIN-based)
Construction	<ul style="list-style-type: none"> • Durable epoxy-polyester powder coated steel casing with louvered forward facing grille • Advanced controls with capacitive sense technology for total flexibility of heating <p>*Note: PLXC300E features a slotted grille</p>
Element	Compact, finned, mineral filled sheathed element
Installation	<ul style="list-style-type: none"> • H-frame wall bracket
Safety	<ul style="list-style-type: none"> • Thermal cut-out. Auto reset type • Overheat detection
IP Rating	IP24
Battery	3V coin cell battery(CR2032) to backup real time clock. Battery life >5 years.
Supply	1.3 metres fitted, 3 core for fused spur installation, 1/N/PE ~230-240 V, 50Hz Class I, with earth wire
Colour / Finish	Metal Chassis, Air Outlet Grille & Control Moulding - Traffic White (RAL 9016)
Approvals	CE, UKCA, BEAB
Guarantee	2 years
Country of Origin	United Kingdom
Manufacturer	Glen Dimplex Heating & Ventilation (Glen Dimplex UK Ltd.)

General

The heater is designed for wall mounting using the wall bracket supplied. It should only be operated when in the upright position as shown - see **Fig. 1** and **Fig. 2**. All models are splash proof to IP24. Before connecting the heater check that the supply voltage is the same as that stated on the heater.

Wall Mounting

IMPORTANT - The wall bracket supplied with the heater must be used and the heater must be installed in the correct orientation. The fixings should be used to secure the bracket to the particular wall on which the heater will be installed. The heater should be positioned observing the minimum clearances stated around the heater - see **Fig. 2**, **Fig. 3** and **Fig. 4**.

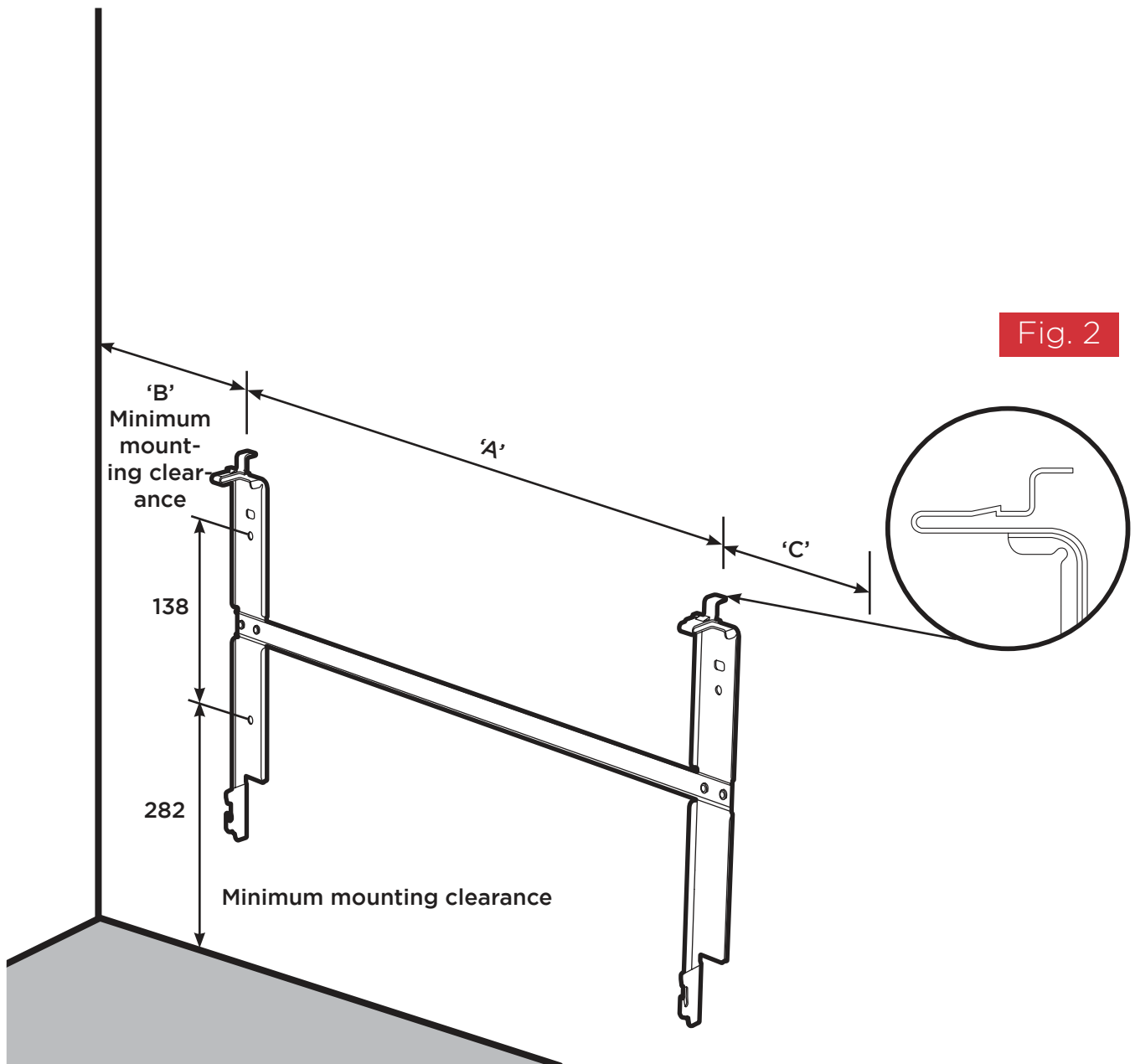
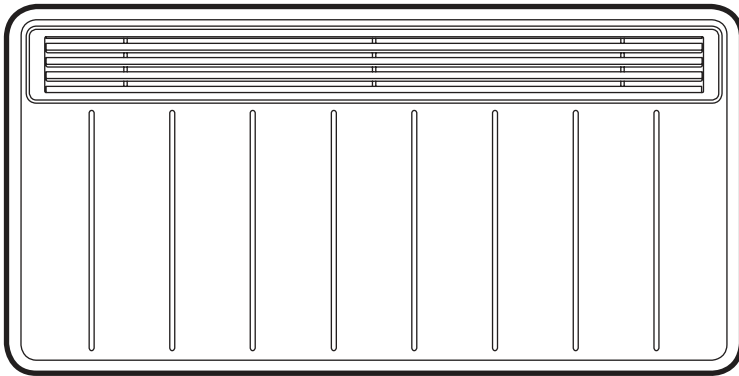

Fig. 2

To mount the heater to the wall:

1. Remove wall mounting bracket from the back of the heater by depressing the spring latch at the side of each bracket - see **Fig.2**.
2. Fix the wall bracket securely to the wall through the four screw holes. Ensure only screw fittings provided are used for the particular wall type.
3. Present the heater to the wall bracket and engage bottom slots in the back with bracket hooks.
4. Press heater into locked position and ensure the clips on the top are engaged.
5. Remove protective film from the user interface



WARNING:

This product is heavy and care should be taken in installation

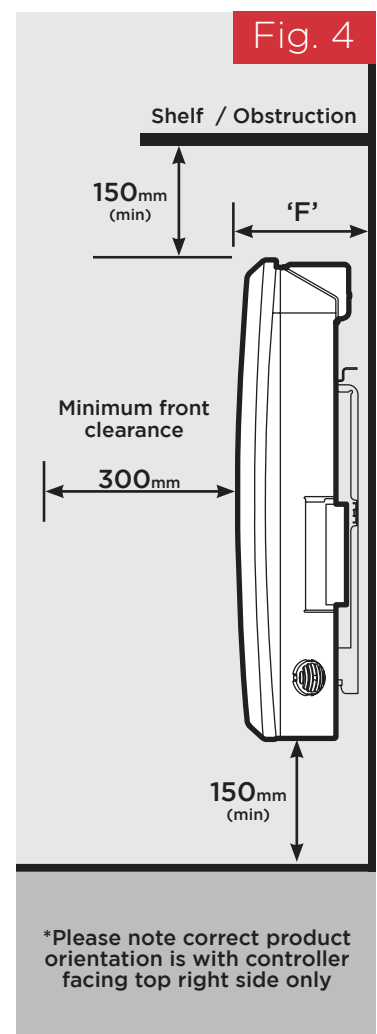
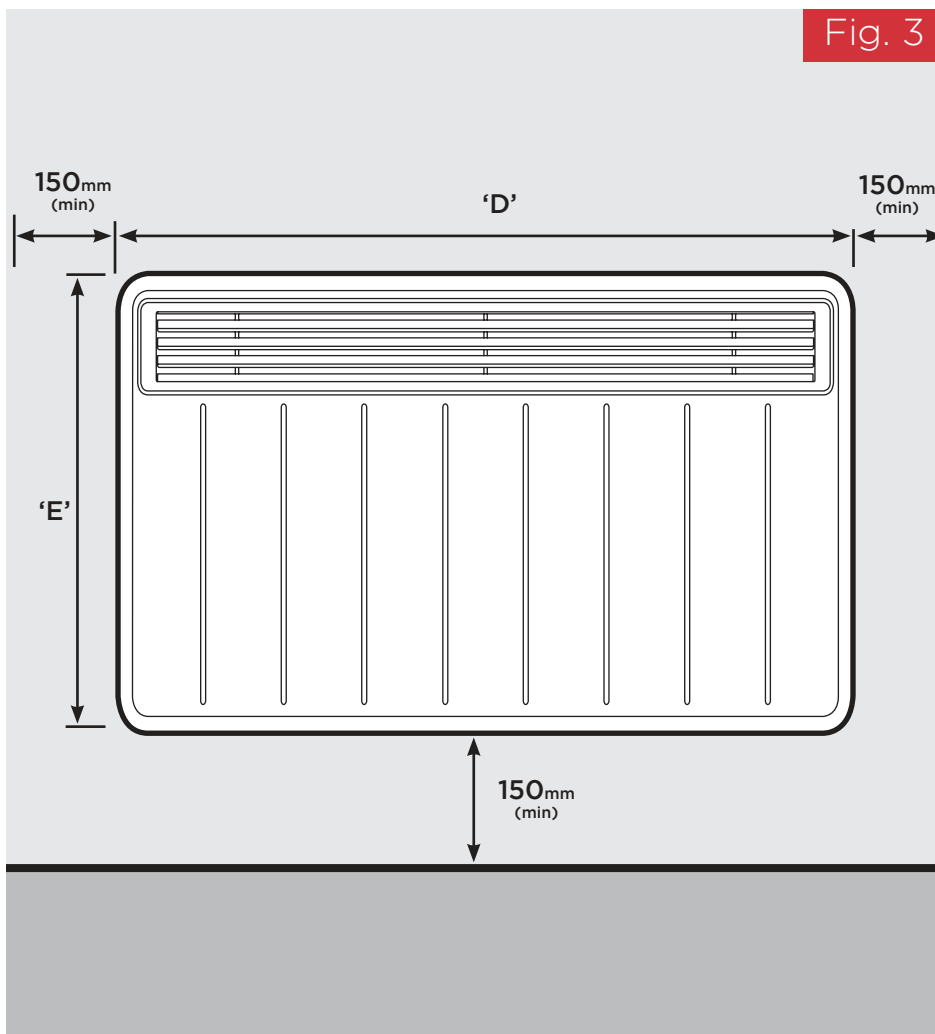

First Time Power-On

A setup wizard will display when the product is powered on for the first time. This will set the following:

- Time, Date, Daylight Savings Time
- Sound On/Off

For information on using the Heaters controls, refer to page 11. The Heater will then take the User to the Home Screen with the 'Out All Day' Timer Mode active.

Important

During initial heat-up, some odour may be emitted due to the newness of materials used in manufacture. This is normal and will disappear after a short period of use. It is however advisable to keep the room well ventilated.

Dimplex • Control

This product is Dimplex Control capable * **.

Control and monitor your heating and hot water with Dimplex Control. Group heaters into zones to easily control and track their energy usage. Any time. Anywhere.

Search for Dimplex Control on your device's app store.



**Requires additional hardware. Sold separately. Visit Dimplex.co.uk for more information.*

***A Dimplex Hub is required for this product to connect to Dimplex Control. For instruction on setting up Dimplex Hub, please refer to the manual. Manuals can be downloaded at Dimplex.co.uk.*

To connect your heater to Dimplex Hub, RF communications must be enabled. See page 23 for comms settings.

The heater controls can be easily adjusted by using the six buttons on the User Interface.

1. The Home Screen shows the options available at each stage of adjustment. Here the current target room temperature is displayed along with the mode of operation. Any use of the Advance function will be displayed here, and pressing **Enter** will show the functions which are enabled.

The currently active mode of operation is displayed at the top of the screen e.g. 'Manual' or 'Out All Day' timer.



When the heater is in a timer profile and trying to achieve or maintain a room temperature, 'Heating On' will be displayed, otherwise, 'Heating Off' will be displayed. The words 'Heating On / Off' will not be displayed in a manual mode of operation.

When the controller buttons have not been pressed for a long period of time, the display will 'sleep' and the text will disappear. The heater is still on and active in whatever Mode it was set to.

2. **Menu** - Displays the Main Menu;
 - Boost - Activate Boost Mode
 - Mode - Set the mode of operation.
 - Settings - Time/Date, Temperature units etc.
3. **Back** returns to the previous screen.
4. The **Up** and **Down** buttons are used to navigate through the menus and adjust the required room temperature on the main screen. The screen colour changes based on the temperature selected, showing deep blue through to bright red.
5. **Enter** is used to enter sub menus and to confirm actions.
6. The **Advance** button is only used when a Timer Mode is active, it allows the timer schedule to be changed temporarily by forcing a 'Heating On' period to begin or end early.

Timer Modes

Timer Modes offer the most efficient mode of operation for a predictable heat demand. Additional functions such as Advance and Boost allow the User to make temporary adjustments to timer schedules for a more flexible operation.

Each timer is broken down into 4 definable 'Heating On' time periods and temperatures per day, for each day of the week. Each day consists of a 24-Hour period, starting and finishing at midnight.

When the heater is in a timer profile and trying to achieve or maintain a room temperature, 'Heating On' will be displayed, otherwise, 'Heating Off' will be displayed.

It is possible to change the Target Temperature of a 'Heating On' period when that period is active. This will temporarily adjust the Target Temperature for just that instance and will not permanently modify the settings for the timer in use.

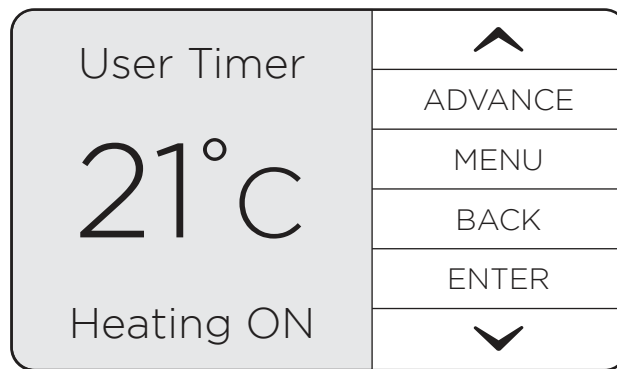

NOTE:

If Adaptive Start is enabled, the heater will maintain the room at the required temperature for the duration of the heating period. To achieve this, the heater will begin heating the room before the start of the heating period to ensure the room is at the required temperature when the period starts.

If Adaptive Start (AS) is disabled, the heater will not operate until the beginning of the heating period. This should be taken into consideration when setting the heating periods.

See page 23 for instruction on enabling/disabling Adaptive Start.

Available Timer Modes

To choose a timer mode, press **Menu** from the home screen. Use the **Up / Down** keys to highlight 'Mode', then press **Enter** to select. 'Timer Mode' should be highlighted. Press **Enter** to select.

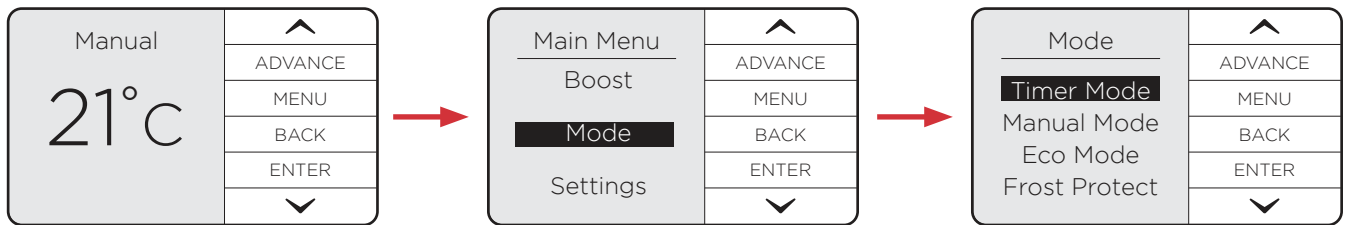

A list of Timer Modes will be shown. Their default settings are shown in the table below.

	Period 1		Period 2		Period 3		Period 4	
User Timer	06:30 - 09:30	21 °C	11:00 - 13:00	21 °C	15:00 - 17:00	21 °C	18:00 - 22:00	21 °C
Home All Day	08:00 - 21:00	21 °C	00:00 - 00:00		00:00 - 00:00		00:00 - 00:00	
Out All Day	07:30 - 08:00	21 °C	17:30 - 22:00	21 °C	00:00 - 00:00		00:00 - 00:00	
Away Mode	Away Mode does not operate in the same way as the other Timers. See section 'Away Mode' on page 16							

Highlight one of the available Timer Modes using the **Up / Down** keys. Press **Enter** to select.

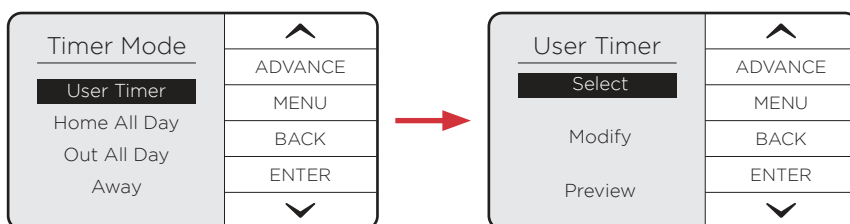

For User Timer, Home All Day and Out All Day, three choices will be available:

- Select - This option will activate the timer
- Modify - This option allows the timer's Heating On times and Target Temperatures to be modified
- Preview - This option displays the timer's configuration. This is handy to quickly check the timer without being able to change any values

Modifying a Timer Mode

Each timer is broken down into 4 definable 'Heating On' periods and temperatures per day.

When Modify is chosen, 'Heating On' period 1 of 4 for the current day is displayed. The current day will be highlighted.



NOTE:

Once modified a Timer Mode must be selected if you want to begin using it.

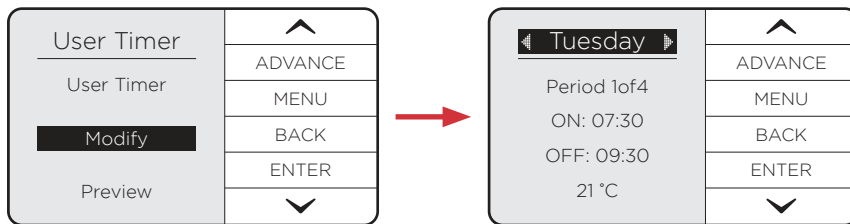

Select and change each option using the **Up**, **Down** and **Enter** buttons.

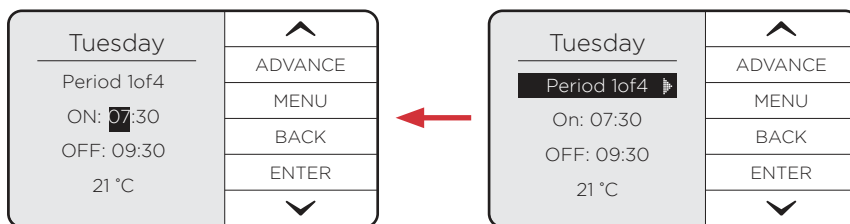

Copy & Paste

To save time when modifying a Timer Mode, the **Advance** button can be used to copy and paste settings. Individual heating periods from one day or every heating period from a day can be copied to another day.

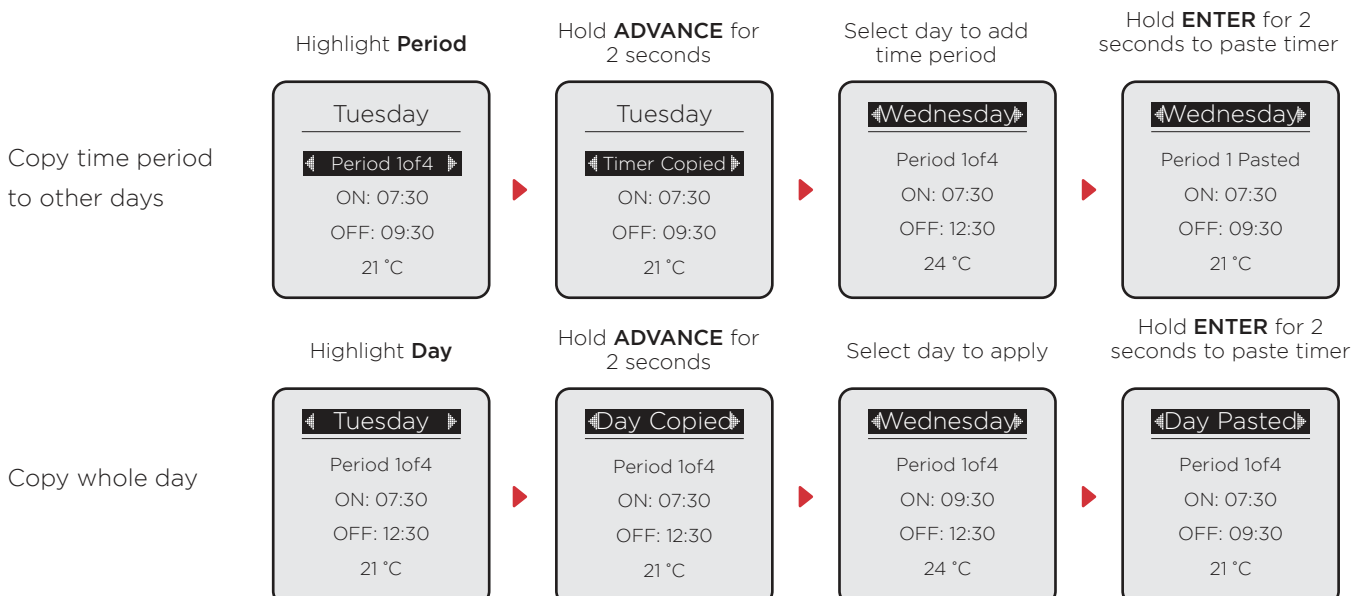

The 'Advance' Function

The **Advance** button is only used when a Timer Mode is active and allows the timer schedule to be changed temporarily. This button allows a 'Heating On' period to begin or end early.

This is useful if you are at home when you had not planned to be, or need to leave when you had planned to have the heating on.

If the heater displays 'Heating Off' and heat is required, press the **Advance** button. If the heater is in 'Heating On' and heat is not required, press the **Advance** button and the heater will stop heating until the beginning of the next 'Heating On' period.

Pre-action State	Action	Impact
Heating On (Timer Mode)	Advance activated	Heating On period switched to Heating Off until the next scheduled 'Comfort On' period.
Heating Off (Timer Mode)	Advance activated	Heating Off switched to Heating On until the next scheduled 'Heating Off' period.
Heating On (Advance Active)	Advance deactivated	Heating On switches to Heating Off. Appliance in following schedule set in the currently active Timer Profile
Heating Off (Advance Active)	Advance deactivated	Heating Off Switches to Heating On. Appliance in following schedule set in the currently active Timer Profile

Away Mode

Away Mode temporarily overrides the active mode before returning the Heater back to the previously active mode.

This is handy if you are temporarily away at the shops or on holiday and want your heating to resume as normal operation automatically when you return.

While active, Away Mode can maintain a minimum room temperature. By default, this is set to 7 °C (frost protection temperature). This can be modified when Away Mode is activated. The heater will also remember the last Away Mode Target Temperature defined while Away Mode is active.

The Away countdown is set in Hours, a Date and a Target Temperature.

The starting Hours and Date show '00 hours' and the current date. Date and Hours are set separately on the heater, making the feature useful for popping out to the shops or going away on holiday.

- The date set is the return date; therefore, Away Mode will end at 23:59 of the day before. E.g. if a return date of 02.02.2018 is set, Away Mode will end at 23:59 on 01.02.2018.
- If hours are set, this will extend Away Mode end from 23:59 on the day before the date set.
- If only hours and no date is set, Away Mode will count from either the current time, or if a date is set.

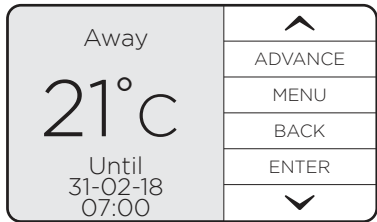
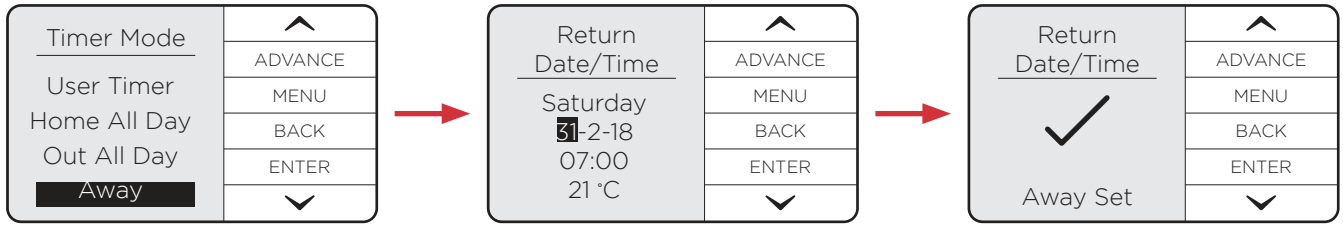

NOTE:

The **Back** button can be used to end the **Away Mode** countdown early.

Continuous Heat Modes

A continuous heat mode is effectively a constant Heating On period. The Heater will remain in a continuous heat mode indefinitely until the mode is changed by the User.

Available Continuous Heat Modes

Each continuous heat mode starts with a default Target Temperature value.

- **Manual**
 - Default 21°C
 - Can be changed from the Home Screen to any value within the Heater’s Temperature Range.
- **Eco**
 - Default 19°C
 - Can be changed from the Home Screen to any value in the Heater’s minimum temperature range (8-18°C)
- **Frost Protection**
 - Default 7°C
 - Not User Definable

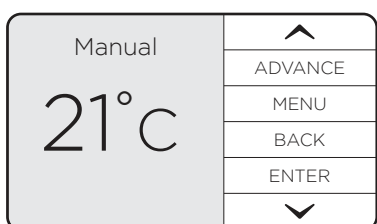
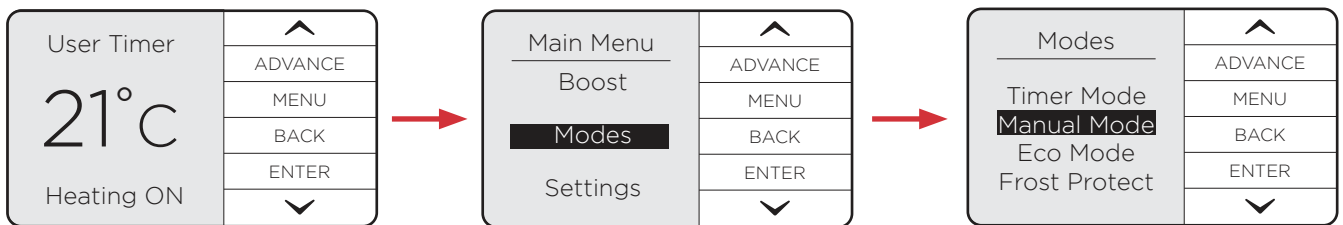

To select a continuous heat mode, first press the **Menu** button. Use the arrow keys to highlight ‘Modes’ and press the **Enter** button. From here, use the arrow keys to highlight the desired continuous heat mode and press **Enter** to select. You will then be returned to the home screen in your chosen mode.

Boost Mode

Boost can be activated at any time, when the product is set to any Timer or Continuous heat mode; even if Advance is active, this mode will provide a temporary 'Boost' of heat. For settings, see Boost settings on Page 22.

Boost Mode can be activated from the Home Screen by pressing **Menu** to access the Main Menu, then pressing Enter to select 'Boost'. 'Boost' will always be listed as the top item on the list.

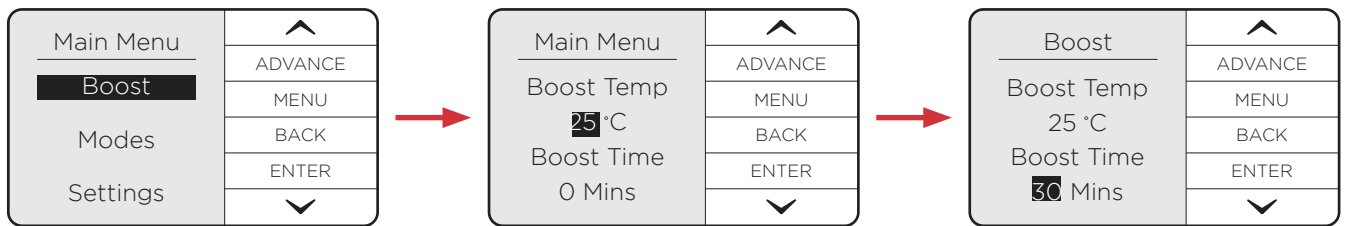

Activating Boost will present two selectable options: Boost Temp (Boost Target Temperature) and Boost Time (Boost Duration Countdown). The default values for these can be set in the Settings Menu.

The **Up**, **Down** and **Enter** buttons can be used to modify these values. Pressing **Back** will end Boost early, restoring the heater back to its previously active mode.

- The Boost Temp can be set to any value within the Heater's Target Temperature Range setting.
- The Boost Time can be increased in the following increments: 30 mins, 1 hour, 2 hours, 3 hours, 4 hours. These increments can be restricted with the Max. Boost Duration Range setting. To modify this range, see Boost Settings on Page 22.

Once the Boost Duration Countdown has reached 0, the Heater will return to the mode that was active before Boost was activated.

Product Locks

Product Locks are methods of locking the heater's controller to restrict access to functions. This can be activated and configured via the Settings Menu. When Product Lock is activated, the heater continues to run in whichever mode is currently active and any/all wireless communications remain active if enabled.

Child Lock

This is the simplest locking method and does not utilise a PIN code. It is toggled on/off on the heater's controller by pressing and holding the **Back** and **Enter** buttons for three seconds.

While Child Lock is active, the heater will continue to operate in whatever mode, with whatever settings it had before the lock was activated.

There are no exception rules with this lock, and the user can only choose to unlock the heater if they wish to change the temperature, modes or settings.

Heater Lock (PIN Lock)

Heater Lock is the most customisable and secure lock on the heater. This allows the heater to be configured in any way, then locked into those settings and modes.

When PIN Lock is activated, pressing the **Menu** button will show one item* that can be selected - 'Unlock'. Selecting 'Unlock' prompts the User to complete the applicable Unlock action:

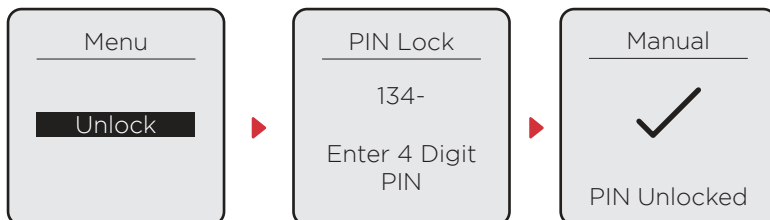

*Unless Boost Mode has been enabled during UI Lock

PIN Lock Exceptions

It is possible to allow the 'Advance' and 'Boost' functions to be enabled/disabled when PIN Lock is active.

There are up to 4 exceptions. These exceptions include:

- Advance

- Ability to activate using the 'Advance Button'

- Boost

- Ability to activate using the 'hotkey' listed in the Main Menu
- Ability to modify the Boost Temperature
- Ability to modify the Boost Duration

'Advance Function' Operation during PIN Lock

If Advance has been enabled during PIN Lock, the **Advance** button will remain active when PIN Lock is active. This will function in the same way it would if the controls were not locked: only if the Heater is Locked into a Timer Mode.

- If Advance is enabled during UI lock, the **Advance** button will function as normal while the Heater is set to a Timer Mode.
- If Advance is Disabled during UI lock, the **Advance** button will not function.

'Boost Function' Operation during PIN Lock

If enabled, Boost will function in the same way as it does when PIN Lock is not active unless modification of Boost Temperature and Boost Duration have been disabled.

Boost Temperature and Boost Duration will be set to the default values when 'Boost' is activated. If either of these values have been disabled during Product lock, when the user tries to modify them the heater's display will show the message 'Disabled' and only the default value can be used. The default values can be changed outside of PIN Lock.

Settings

To navigate to the settings menu, from the home screen:

Press the **Menu** button to access the Main Menu. Use the **Up / Down** buttons to highlight 'Settings', then press the **Enter** button. Each of the following headings relate to an item in the settings menu.

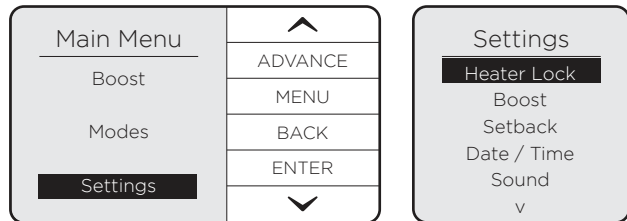

Heater Lock

Set Lock

Heater (PIN) Lock can be enabled here by highlighting 'Heater Lock' and pressing **Enter** to enter the Heater Lock menu. Highlight 'Set Lock', press **Enter**, enter a 4-digit PIN code, then press **Enter** to lock the heater.

Lock Settings

Before PIN Lock is enabled, the User can select 'Lock Settings' to enable/disable the Advance and/or Boost functions, as well as enable/disable modification of the Boost Temperature and Boost Duration. See below.

Boost Lock

Three settings can be modified within this Menu:

- Enable / Disable - The 'Boost' Menu Item can be Enabled/Disabled while PIN Lock is active.
- Temperature Rule - Modifiable Boost Temperature while PIN Lock is active
 - Enable - While Boost is active, the User can modify this value as they normally would
 - Disable - Default value will be loaded. When the user tries to modify the value, the UI will show the following text: 'Disabled'.
- Duration Rule - Modifiable Boost Duration while PIN Lock is active.
 - Enable - While Boost is active, the User can modify this value as they normally would
 - Disable - Default value will be loaded. When the user tries to modify the value, the UI will show the following text: 'Disabled'

Advance Lock

- Enable / Disable - This setting allows the User to Enable or Disable the **Advance** button while UI Lock is active.

Boost Settings

Default Boost Target Temperature

This is the default Boost Target Temperature that is used when 'Boost Mode' is activated.

Defined as a temperature value, this must be within the Heater's Target Temperature Range.

If the Target Temperature Range settings are changed then the Default Boost Temperature Range will be automatically changed to the closest valid temperature within Target Temperature Range.

Max. Boost Duration

This is the maximum length of time that the user is able to activate 'Boost' for.

Shown in minutes (when under an hour) or hours (if over an hour) in the following increments: 30 mins, 1 hour, 2 hours, 3 hours, 4 hours.

The value chosen will be the max allowed when boost is activated.

Setback Settings

Setback is a function that only modifies Timer Mode operation. When Setback is enabled it overrides any Heating Off period to maintain a constant temperature.

This can be used to prevent the room temperature from falling below a minimum value while there is no demand for heat (Heating Off).

The value of this temperature is restricted to a value between 7 and 18 °C. This is because Setback should not be treated as a regular Heating On period.

Date & Time Settings

This allows the Time, Date and Daylight Savings Time settings to be modified.

Sound Settings

Audio feedback when the user presses a button can be enabled or disabled here.

'Comms' (Communications) Settings

This allows Wireless Connectivity features to be enabled or disabled. Entering this menu item will display a list of available communications methods to that heater.

Adaptive Settings

Open Window Detection

This is a global setting that can interrupt any active mode. Activating this setting enables Open Window Detection to switch the Heater to a 'Heating Off' state if it detects an open window in the room it's operating in.

Adaptive Start

Adaptive Start is predictive function that only modifies Timer Mode operation. This function models the heating characteristics of the room and uses that information to pre-heat the room for only the time required to achieve the Target Temperature by the start of the 'Heating On' period.

For example, with Adaptive Start off, the 'Heating On' time is the time that the Heater will begin to try and achieve the Target Temperature. With Adaptive Start On, the Heater will begin to heat the room before the User-defined Heating On time so that the Target Temperature is achieved when the User defined the 'Heating On' start time.



NOTE: Adaptive Start

This is a continuously learning function and will be affected daily by changes in the heater's environment. The heater will take into account the starting temperature of the room so pre-heating should remain accurate.

It is important that if multiple heaters are installed in one room that all heaters have the Adaptive Start (AS) function enabled. If this is not the case, heaters with AS enabled will pre-heat the room to the desired target temperature before the heaters with AS disabled attempt to output heat.

It is likely that if two heaters are required in one room, that the output from one heater may not be sufficient to heat the room alone. This may cause the pre-heat time calculation to extend to a large degree if the heaters do not all have AS enabled. This may lead to heat at unwanted times and excessive wear to some heaters.

A two-hour limit is enforced on the calculation, however, if all heaters have AS enabled and pre-heating takes over one-hour, extreme environmental factors may be affecting the calculation or the heaters may be under sized for the room. Please contact us for support if your pre-heat time seems excessive.



NOTE: Open Window Detection

In environments where the product may read sudden decreases in temperature, this feature may activate in error. This can occur in drafty or poorly insulated environments as well as if the heater is undersized for the room. This feature should be disabled using the instructions above if activating for reasons other than the intended purpose. If you think that your environment is not as described here and this feature is activating, please contact our customer care team with the details on the rear page of this document.

Advanced Settings

These settings can be used to significantly change the operation of the heater. While useful for very specific requirements, there is a much higher risk of User error and unintended consequences of changing these settings compared to the top-level settings menu. It is recommended that these settings are only modified by trained professionals.

To navigate to the Advanced settings menu, from the home screen:

Press and hold **Advance** and **Menu** buttons for 5 seconds.

Each of the following headings relate to an item in the settings menu.

Temperature Settings

Temp Units (Temperature Units)

This setting defines which temperature units are displayed on the heater. The default is °C, but °F can be set. When °F is selected, the heater will convert °C values to °F and round to the nearest number.

Service Settings

Room Temp (Temperature) Offset

- Panels and Storage Heaters
- Service personnel use only.
- Allows the manual adjustment of electronic thermostat reading by +/-0.2°C

Factory Reset

This setting allows the User to restore the default values to all settings. Returning the product to the same state that it left the factory.

Error Codes

Error codes are to be defined as a list. Each error code must be defined as a parameter that Central Control can read.

Fault Code	Description
20	Component thermistor hardware fault
21	
22	
23	
24	
30	Component overheat
32	
33	
34	
40	Internal serial comms error
41	Heating element fault
50	Open window detected
52	Heat output disabled
53	Time loss error
54	Occupancy sensor not detected
55	Unknown error
60	Wireless communication module error
61	Hub connection error

IMPORTANT:

Before replacing the battery ensure the heater is isolated from the electricity supply.



NOTE:

Battery should be disposed of in an appropriate manner

This product is fitted with a replaceable battery in the controls. To replace the battery, follow the steps below.

1. Unhinge the heater from the wall using the clips shown in **Fig. 2** (page 7) and locate the battery module.
2. Slide the catch and pull module from the controls.
3. Remove the coin cell battery and replace.
4. Slide module back in place, ensuring clip is engaged.

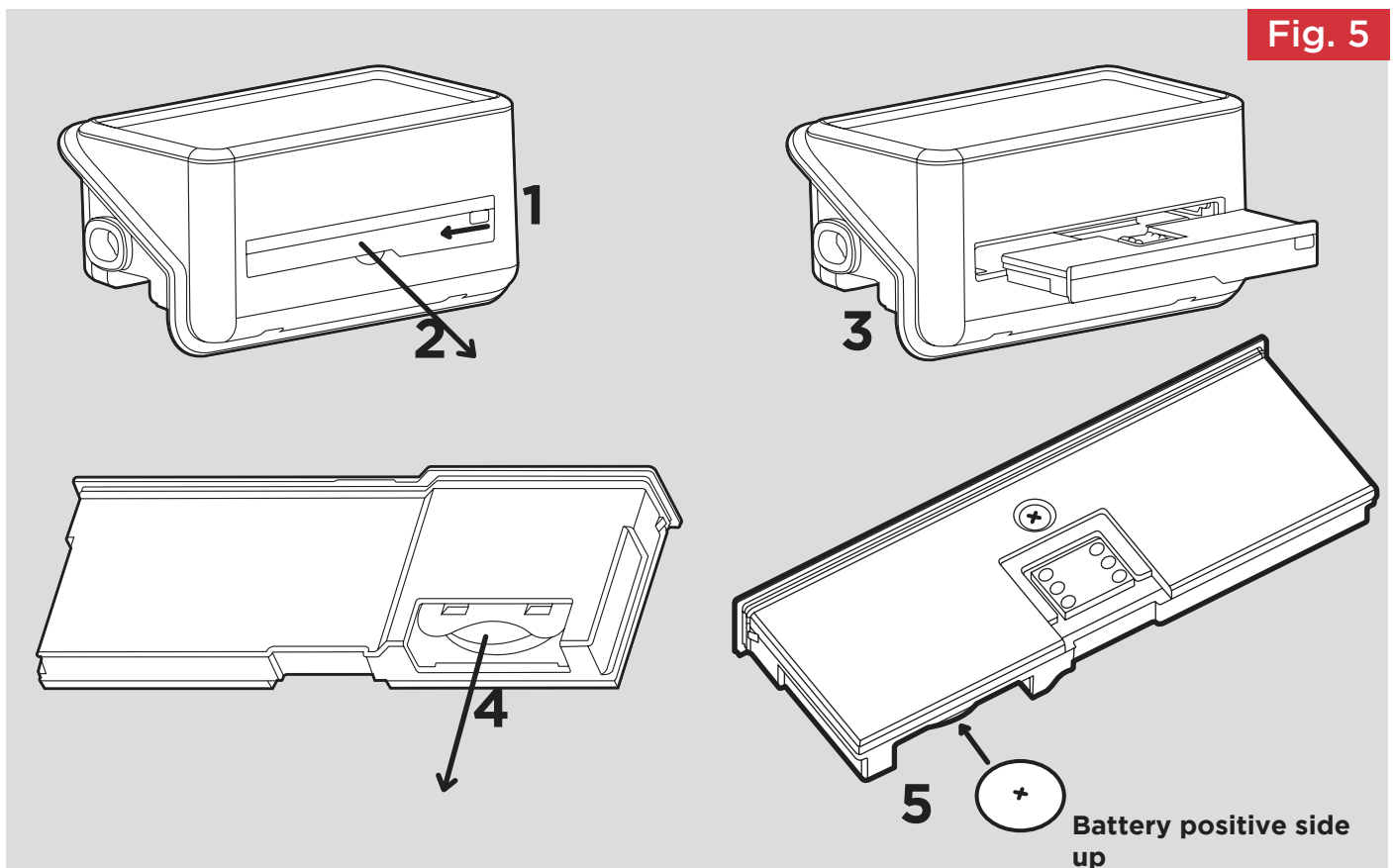

RF Module Installation

1. Unhinge the heater from the wall using the clips shown in **Fig. 2** (page 7) and locate the battery module, indicated in **Fig. 5**
2. Slide the catch and pull module from the controls (**See Fig 5; 1-3**).
3. Replace the tray with the radio frequency module
4. Power the product on and make sure that the RF comms are enabled. Comms settings will be located in the settings menu (**see page 22**)

Important

During the initial operation, some odour may be noticed due to the newness of materials used in manufacture. This is normal and will disappear after a short period of use. It is however advisable to keep the room well ventilated

Cleaning

WARNING - ALWAYS DISCONNECT FROM THE POWER SUPPLY BEFORE CLEANING THE HEATER.

Before commencing cleaning, isolate the heater from the electrical supply and allow it to cool. The outside can be cleaned by wiping it over with a soft dry cloth. Do not use abrasive cleaning powders or furniture polish, as this can damage the surface finish. To release the heater from the wall bracket for cleaning or redecoration, depress the latch on both brackets (See **Fig. 2, page 7**) and hinge forward.

Guarantee



To view the full guarantee terms and conditions scan this QR code using your smartphone or go to <https://www.gdhv.co.uk/guarantee-terms-and-conditions>.

Your Product is manufactured by Glen Dimplex UK operating as Glen Dimplex Heating & Ventilation. GDHV designs and manufactures products to ensure they deliver reliable service for normal use in domestic dwellings and, where specified by us, in light commercial premises.

GDHV products are individually tested before leaving the factory, Your product comes with a 2 year parts and labour guarantee for repair or replacement of faulty goods and/or partial refund in the event that a repair or replacement is not available.

Your guarantee is provided by Glen Dimplex UK Ltd operating as Glen Dimplex Heating & Ventilation Ltd, Millbrook House, Grange Drive, Southampton SO30 2DF. Terms and conditions apply.

The GDHV guarantee does not in any way diminish or affect your statutory consumer rights in connection with your product.



If you experience a problem with your product during or after the guarantee period, visit our online help centre:

support.dimplex.co.uk

Please note for support you will need the model and serial number of your product and a description of the fault which has occurred.



Important: For electrical products sold within the European Community. At the end of the electrical products useful life it should not be disposed of with household waste. Please recycle where facilities exist. Check with a Local Authority or retailer for recycling advice in your country. Batteries should be disposed of or recycled in accordance with WEEE Directive 2012/19/EU. Packaging should be recycled where possible.

www.dimplex.co.uk

 **Dimplex**[®]

Glen Dimplex Heating and Ventilation
Millbrook House, Grange Drive, Hedge End, Southampton, SO30 2DF



© Glen Dimplex. All rights reserved. Material contained in this publication may not be reproduced in whole or in part, without prior permission in writing of Glen Dimplex.