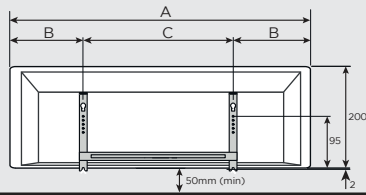
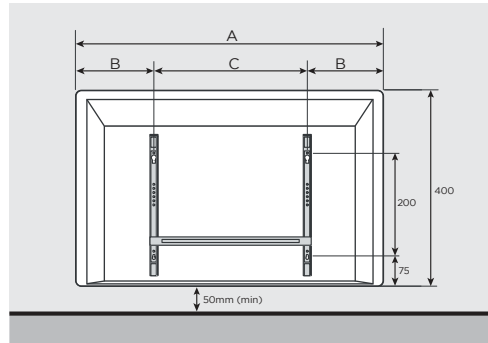

Fig. 1



| Dimensions | | | |
|------------|------|------|------|
| Watt | A mm | B mm | C mm |
| 500 | 727 | 214 | 300 |
| 750 | 1027 | 214 | 600 |
| 1000 | 1327 | 364 | 600 |



| Dimensions | | | |
|------------|------|------|------|
| Watt | A mm | B mm | C mm |
| 250 | 427 | 139 | 150 |
| 500 | 527 | 164 | 200 |
| 750 | 627 | 164 | 300 |
| 1000 | 727 | 214 | 300 |
| 1250 | 927 | 264 | 400 |
| 1500 | 1027 | 214 | 600 |
| 2000 | 1127 | 264 | 600 |

THESE INSTRUCTIONS SHOULD BE READ CAREFULLY AND RETAINED FOR FUTURE REFERENCE

IMPORTANT SAFETY ADVICE

When using electrical appliances, basic precautions should always be followed to reduce the risk of fire, electrical shock, and injury to persons, including the following:

IMPORTANT: The wall bracket supplied with the appliance must be used.

WARNING: Do not use this heater in the immediate surroundings of a bath, a shower or a swimming pool

IMPORTANT: If the heater is installed in a room containing a bath or shower, it must be so installed that switches and other controls cannot be touched by a person using a bath or shower.

WARNING: In order to avoid overheating, do not cover the heater. Do not place material or garments on the heater, or obstruct the air circulation around the heater, for instance by curtains or furniture, as this could cause overheating and a fire risk.

NEVER cover or obstruct in any way the heat outlet slots at the top of the heater or the air inlet slots in the base of the heater.

This heater carries the warning symbol indicating that it must not be covered.

CAUTION: Some parts of this product can become very hot and cause burns. Particular attention has to be given where children and vulnerable people are present.

This appliance can be used by children aged from 8 years and above and by persons with reduced physical, sensory or mental capabilities or lack of experience and knowledge if they have been given supervision or instruction concerning use of the appliance in a safe way and understand the hazards involved.

Cleaning and user maintenance shall not be

carried out by children without supervision.

Children of less than 3 years should be kept away unless continuously supervised.

Children aged from 3 years and less than 8 years shall only switch on/off the appliance provided that it has been placed or installed in its intended normal operating position and they have been given supervision or instruction concerning use of the appliance in a safe way and understand the hazards involved.

Children aged from 3 years and less than 8 years shall not plug in, regulate and clean the appliance or perform user maintenance.

Note that due care and consideration must be taken when using this heater in series with a thermal control, a program controller, a timer or any other device that switches on the heat automatically, since a fire risk exists when the heater is accidentally covered or displaced.

If the supply cord is damaged it must be replaced by the manufacturer or service agent or a similarly qualified person in order to avoid a hazard

WARNING: Servicing and product repairs should only be undertaken by the manufacturer's approved service agent or a similarly qualified person, using only exact manufacturer approved spare parts.

IMPORTANT: The supply circuit to the heater must incorporate a double pole isolating switch having a contact separation of at least 3mm.

WARNING: Packaging should be disposed of responsibly as the EPS used could be a potential choking hazard for children.

WARNING: Do not locate the heater immediately below a fixed socket outlet or connection box.

Energy Related Product Directive

This product complies with Lot20 of the Energy Efficiency Directive (2015/1188)

| Model Identifier(s): | | DTD2R 05 | DTD2R 07 | DTD2R 10 | DTD2R 12 | DTD4R 05 | DTD4R 07 | DTD4R 10 | DTD4R 15 | DTD4R 20 |
|---|---------------------|----------|----------|----------|----------|----------|----------|----------|----------|----------|
| Nominal heat output | P _{nom} | 500 W | 750 W | 1000 W | 1250 W | 500 W | 750 W | 1000 W | 1500 W | 2000 W |
| Minimum heat output (indicative) | P _{min} | 500 W | 750 W | 1000 W | 1250 W | 500 W | 750 W | 1000 W | 1500 W | 2000 W |
| Maximum heat output | P _{max,c} | 500 W | 750 W | 1000 W | 1250 W | 500 W | 750 W | 1000 W | 1500 W | 2000 W |
| Auxiliary electricity consumption | | | | | | | | | | |
| At nominal heat output | e _{lmax,c} | 0 | 0 | 0 | 0 | 0 | 0 | 0 | 0 | 0 |
| At minimum heat output | e _{lmin} | 0 | 0 | 0 | 0 | 0 | 0 | 0 | 0 | 0 |
| In standby mode | e _{lSB} | <0.0005 | <0.0005 | <0.0005 | <0.0005 | <0.0005 | <0.0005 | <0.0005 | <0.0005 | <0.0005 |
| Control options | | | | | | | | | | |
| Electronic room temperature control plus week timer | | Yes | Yes | Yes | Yes | Yes | Yes | Yes | Yes | Yes |
| With distance control option | | Yes | Yes | Yes | Yes | Yes | Yes | Yes | Yes | Yes |

General Information

The heater is designed for wall mounting using the wall bracket supplied. It should only be operated when in the upright position as shown (see Fig. 1). All models are splash proof to IP24. Before connecting the heater check that the supply voltage is the same as that stated on the heater.

Electrical Connection

WARNING:- The electrical installation of this heater must be carried out by a suitably qualified or trained electrician, and be in strict accordance with the current wiring Regulations BS 7671. The supply must be connected via a switched fused spur with a fuse rated suitably for the appliances flex. Failure to follow these instructions will mean that the manufacturer's instructions have not been adhered to. THERE ARE NO EXCEPTIONS.

Mains lead are coloured in accordance with the following code:

BLUE: NEUTRAL

BROWN: LIVE

The heater is fitted with a length of flexible cable type H05VV-F size 2 x 1.0mm² models for connection to the fixed wiring of the premises through a suitable connection box positioned adjacent to the heater. A means for disconnection must be incorporated in the fixed wiring of the premises in accordance with the current wiring regulations. Products that are supplied without a plug are for installation into the fixed wiring of the property, via a suitable double pole switched fused spur with a fuse rated suitably for the appliances flex.

WARNING: This heater must not be connected to the electricity supply via an external switching device.

Wall Mounting

IMPORTANT The wall bracket supplied with the heater must be used and the heater must be installed in the correct orientation. The fixings should be used to secure the bracket to the particular wall on which the heater will be installed. The heater should be positioned observing the minimum clearances stated around the heater (see Fig. 2).



WARNING: This product is heavy and care should be taken in installation

Ensure minimum distances are maintained as shown in Fig. 2 below

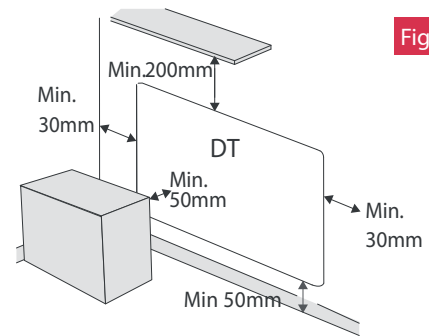
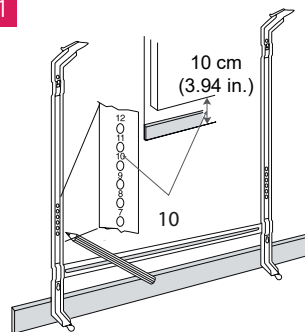

Fig. 2

Wall Bracket Installation Steps:

STEP 1



STEP 2

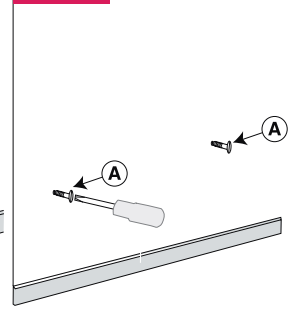

1. Use the wall bracket as a measuring device to place the heater on the wall.
2. Mark the location for the two bottom screws (A-A) and fasten the two screws in the wall.

STEP 3

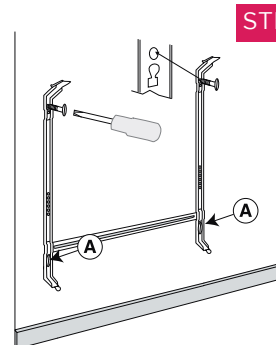

STEP 4

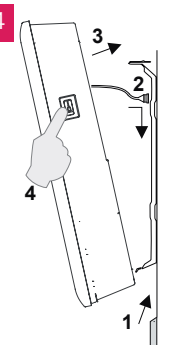

3. Place the wall bracket onto the bottom screws (A-A). Then fasten the wall bracket with the top screws.
4. Place the heater on the wall bracket (1), secure the tilt strap (2) and click the heater onto the top catches (3).
5. Once the heater has been connected through a suitable connection box to the fixed wiring of the premises, the heater can be switched on (4).

Temperature Settings

Red = Comfort

Adjust Comfort temperature by pressing + or -

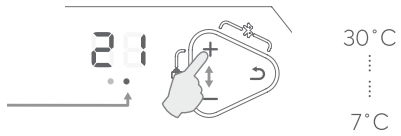

To switch between "Comfort" and "Eco," press '↵'



Green = Eco

Adjust Eco temperature by pressing + or -

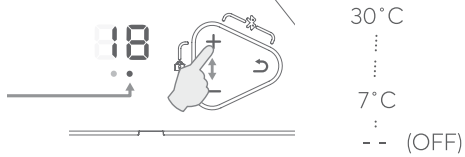

Download Capa Connect Application



Download the Capa Connect app to your smartphone or tablet, and follow the instructions on screen.



Setup Capa Connect & Voice assistant



Use your smartphones camera to scan the QR code and open web instructions. Click on Adding heater to a Site for step by step instructions.



Heating ON



Yellow =

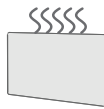

Yellow LED will remain lit when element is in heating state.

Override



Pressing '↵' overrides the status from Comfort to Eco or vice versa. The override is terminated automatically upon the next event in the program, or at 00:00. (Correct time setting requires WiFi connection). If the red/green light flashes, the heater is in override mode.

Key Lock

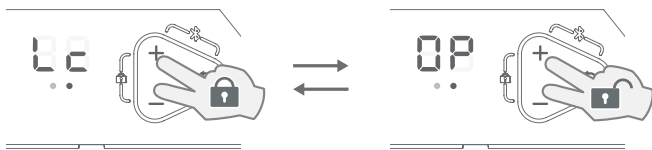

To activate/deactivate key lock, press '+' and '-' simultaneously.

Application Setup



To add a heater to your site, press the "+" button in the top, right corner of the Control screen.

Enter the product identification code (GDID) and PIN code. Both codes are found on a label at the back of the heater. The codes can be entered manually, or by scanning the QR code on the label.

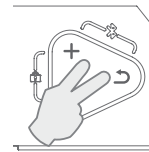
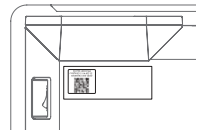

The heater needs to be paired with your WiFi network. This is done by activating the Bluetooth (BLE) discovery mode on the heater.

To activate Bluetooth search, press '+' and '↵' simultaneously for 3 seconds.



Blue = Away



OFF



Once paired the Bluetooth LED will remain lit.

Make sure Bluetooth is activated on your smartphone or tablet, and follow the instructions in the app. For Android devices, device location services must also be switched on.

Select your preferred WiFi network from the list and enter the WiFi password when prompted.

! Opening up full programme schedules is only available via the APP.

Your Guarantee



To view the full guarantee terms and conditions scan this QR code using your smartphone or go to <https://www.gdhv.co.uk/guarantee-terms-and-conditions>.

Your Product is manufactured by Glen Dimplex UK operating as Glen Dimplex Heating & Ventilation. GDHV designs and manufactures products to ensure they deliver reliable service for normal use in domestic dwellings and, where specified by us, in light commercial premises.

GDHV products are individually tested before leaving the factory, Your product comes with a 2 year parts and labour guarantee for repair or replacement of faulty goods and/or partial refund in the event that a repair or replacement is not available.

Your guarantee is provided by Glen Dimplex UK Ltd operating as Glen Dimplex Heating & Ventilation Ltd, Millbrook House, Grange Drive, Southampton SO30 2DF. Terms and conditions apply.

The GDHV guarantee does not in any way diminish or affect your statutory consumer rights in connection with your product.

If you experience a problem with your product during or after the guarantee period, visit our online help centre:

<https://www.dimplex.co.uk/gdhv-help-centre>

If you cannot solve your issue online, contact the customer care team on 0344 879 3588

Please note that when you contact us you will need to provide the model and serial number of your product and a description of the fault which has occurred.

Why Register Your Products With Us?



Faster Customer Service

Once you have registered your product, our customer service team will be able to quickly access your details when you contact us, allowing them to help you sooner.



Guarantee Management

Upon registration, you will receive a confirmation email including a summary of your product guarantee, a copy of our terms and conditions and a copy of your proof of purchase (optional).



Product Recall Notification

If your product is registered you will automatically be contacted with applicable safety notifications, or in the unlikely event of a product recall.

Your product is under guarantee for 2 years from the date of purchase or the date of delivery of the product, if later. The 2 year guarantee is extended for an additional 3 years when you register the product with Dimplex, within 28 days of purchase. If you do not register the product with Dimplex within 28 days, your product will remain guaranteed for 2 year only.

To validate your extended guarantee register with us online at: <http://register.dimplex.co.uk> or simply scan this QR code using your smartphone.



If you do not have access to the internet, call us on 0344 879 3588.

On registering you will automatically receive a copy of the terms and conditions of your guarantee, which can also be downloaded at any time from <https://www.gdhv.co.uk/guarantee-terms-and-conditions>. If you do not have access to the internet, call us on 0344 879 3588 and we will send them to you by post.

Recycling



For electrical products sold within the European Community.

At the end of the electrical product's useful life it should not be disposed of with household waste.

Please recycle where facilities exist. Check with your Local Authority or retailer for recycling advice in your country.

Batteries should be disposed of or recycled in accordance with WEEE Directive 2012/19/EU. Packaging should be recycled where possible.

 **Dimplex**[®]

Customer Helpline: 0344 879 3588
www.dimplex.co.uk

Glen Dimplex Heating & Ventilation
Millbrook House, Grange Drive, Hedge End, Southampton, SO30 2DF

© Glen Dimplex UK Limited. All rights reserved. Material contained in this publication may not be reproduced in whole or in part, without prior permission in writing of Glen Dimplex



This product complies with the European Safety Standards EN60335-2-30 and the European Standard Electromagnetic Compatibility (EMC) EN55014-1, EN55014-2, EN61000-3-2 and EN61000-3-3 which cover the essential requirements of EMC Directive 2014/30/EU and the LVD Directive 2014/35/EU.