

e-MatriX | 800/650 III

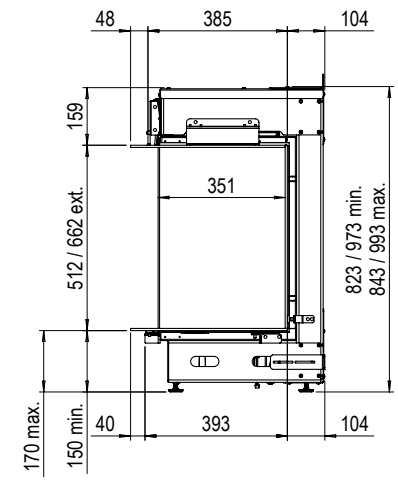
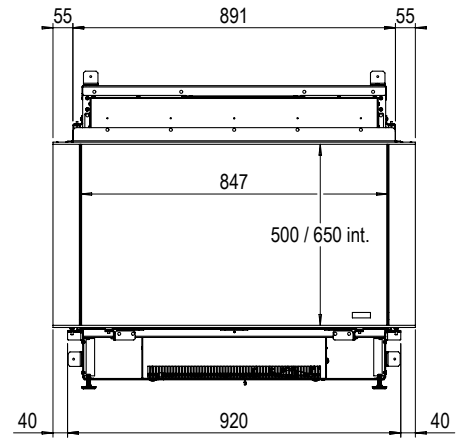
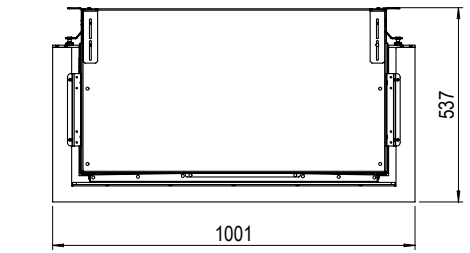

Specifications e-MatriX 800/650 III

Type	Built-in
Model	Three-sided model
Exterior dimensions WxHxD in mm	995 x 940 x 552
Fire display WxHxD in mm	843 x 650 x 351
System	e-MatriX burner
Decoration	Log set
Back walls	Smooth steel
Remote	e-MatriX
Power (kW)	2
Operating system	N/A
Energy label	N/A

For the e-MatriX series, whilst stocks last, the fire casing may be 32mm lower than noted on the drawings in these brochures. After delivery, check the height of the fire casing to prevent misunderstandings. The very latest drawings of Faber fires are available on the website www.faberfires.com

Note: The new log set for the e-MatriX series (season 20/21) is different from the log set shown in the images. New log set does not contain glow bed lighting.

For more information, please take a look at the website

www.faberfires.com

There is **so much to tell...**