

LINEAR FIRE

e-MatriX | 1050/400 II

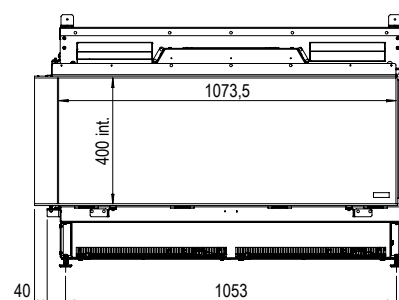
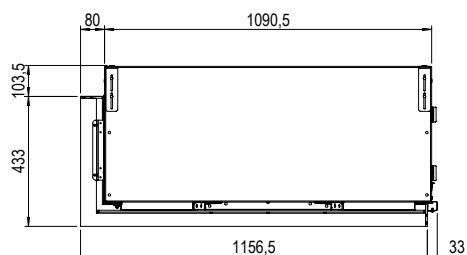
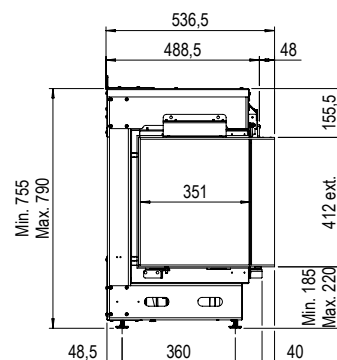

Specifications e-MatriX 1050/400 II

Type	Built-in
Model	Two-sided model
Exterior dimensions WxHxD in mm	1190 x 755 x 537
Fire display WxHxD in mm	1074 x 400 x 351
System	e-MatriX burner
Decoration	Log set or Carrara pebbles or Acrylic ice
Back walls	Smooth steel
Remote	e-MatriX/app
Power (kW)	2
Operating system	N/A
Energy label	N/A

DECORATION OPTIONS



OPTIONS

- Anti-reflective glass
- Glass back wall black
- Top lighting
- Under lighting
- Wall brackets
- Pump kit

There is **so much to tell...**

For more information, please take a look at the website

www.faberfires.com